

Auburn Bearing & Manufacturing T-100

BALL THRUST BEARING ENCLOSED STYLE SELF CONTAINED "AUBURN" GROOVES

Auburn Enclosed Style T-100 Ball Thrust Bearing is recommended for use in exposed locations where a protection from dust, dirt, or other foreign matter is required. It is self-contained, the two races and balls being held together as a unit by the outside sleeve.

MOUNTING INSTRUCTIONS:

Enclosed Style T-100 Ball Thrust Bearing is generally installed so that the race "A" is centered by the shaft and rotates with it. The race with the sleeve attached to it and having a clearance bore "A'" seated against a fixed part of the machine and is stationary. If installed in a recess, a clearance of one-eighth inch or more should be left around the outside diameter "B" so that the shaft should wear in its journal bearings, the thrust bearing will be free to follow without cramping or wedging the balls.



Auburn Bearing & Manufacturing T-100

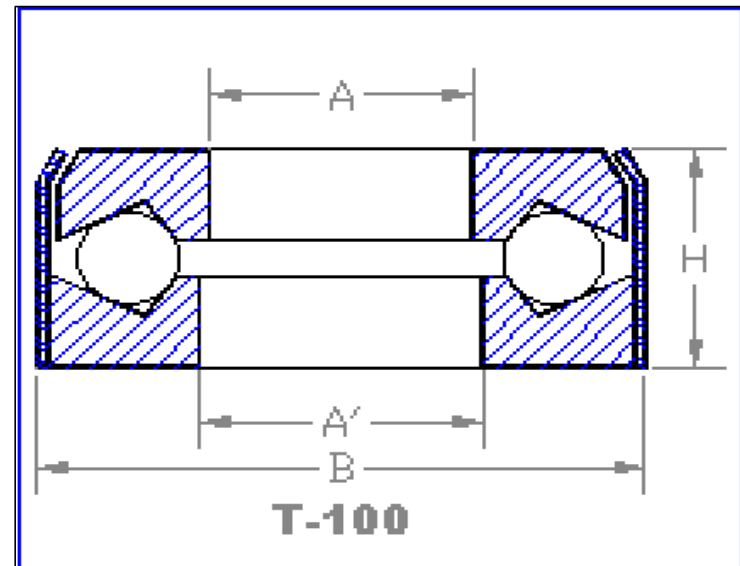

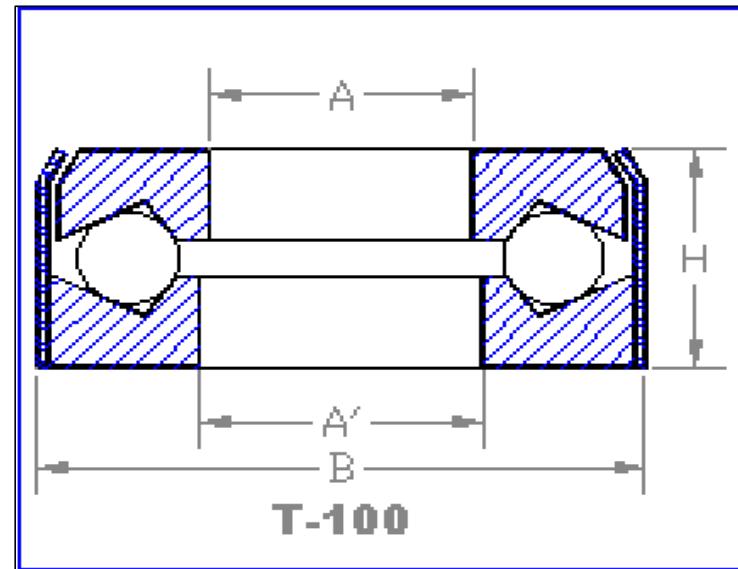

Auburn Bearing & Manufacturing T-100

DIMENSIONS IN INCHES

* H tolerance + or - .005

THRUST LOAD CAPACITY IN LBS. AT VARIOUS SPEEDS

Bearing Number	A Bore	A Tolerance	A' Bore	A' Tolerance -.000	B Outside Diameter	B Tolerance + or -	* H Height	Balls No. - Size	Bearing Weight in Lbs.	25	100	500	1500
										RPM	RPM	RPM	RPM
00	5/16	+.001 +.003	21/64	+.015	11/16	.015	5/16	12 - 1/8	.03	600	395	245	175
0	3/8	+.001 +.003	25/64	+.015	3/4	.015	5/16	13 - 1/8	.04	630	415	260	185
3/8	3/8	+.001 +.003	25/64	+.015	1 3/16	.015	1/2	12 - 7/32	.11	1730	1140	700	505
1/2	1/2	+.001 +.003	17/32	+.015	1 3/16	.015	3/8	17 - 5/32	.08	1155	760	470	335
1	1/2	+.001 +.003	17/32	+.015	1 3/16	.015	5/8	10 - 1/4	.13	1930	1275	785	565
2	5/8	+.001 +.003	21/32	+.015	1 3/8	.015	5/8	12 - 1/4	.16	2225	1465	905	645
3	3/4	+.001 +.003	25/32	+.015	1 1/2	.015	11/16	14 - 1/4	.19	2480	1635	1005	725
4	7/8	+.001 +.003	29/32	+.015	1 13/16	.015	11/16	13 - 5/16	.30	3750	2350	1450	1040
5	15/16	+.001 +.003	31/32	+.015	2	.015	13/16	12 - 3/8	.44	4700	3095	1905	1370
6	15/16	+.001 +.003	31/32	+.015	2	.015	11/16	15 - 5/16	.36	3940	2595	1600	1150
7	1	+.001 +.003	1 1/32	+.015	2	.015	13/16	12 - 3/8	.41	4700	3095	1905	1370

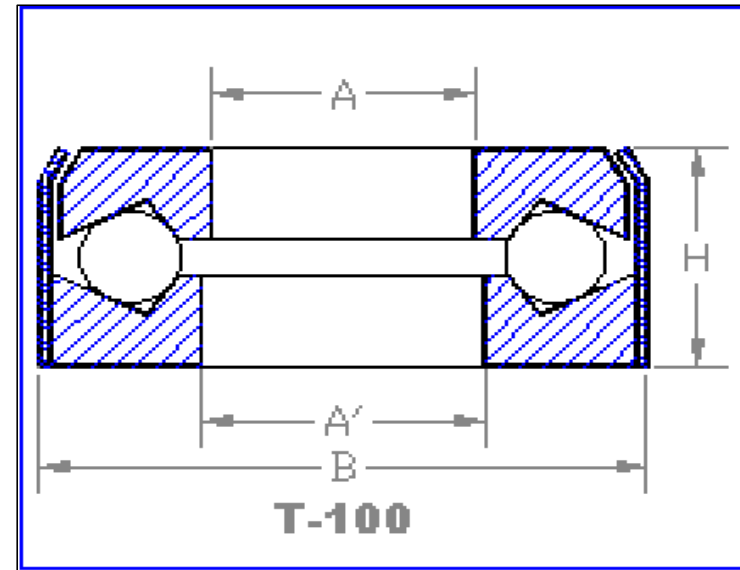

Auburn Bearing & Manufacturing T-100

DIMENSIONS IN INCHES

* H tolerance + or - .005

THRUST LOAD CAPACITY IN LBS. AT VARIOUS SPEEDS

Bearing Number	A Bore	A Tolerance	A' Bore	A' Tolerance -.000	B Outside Diameter	B Tolerance + or -	* H Height	Balls No. - Size	Bearing Weight in Lbs.	THRUST LOAD CAPACITY IN LBS. AT VARIOUS SPEEDS			
										25 RPM	100 RPM	500 RPM	1500 RPM
8	1	+.001 +.003	1 1/32	+.015	2	.015	11/16	15 - 5/16	.34	3940	2595	1600	1150
9	1 1/16	+.001 +.003	1 3/32	+.015	2	.015	11/16	15 - 5/16	.33	3940	2595	1600	1150
10	1 1/16	+.001 +.003	1 3/32	+.015	2 3/16	.015	13/16	13 - 3/8	.53	4985	3285	2025	1455
11	1 1/8	+.001 +.003	1 5/32	+.015	2 3/16	.015	15/16	13 - 3/8	.63	4985	3285	2025	1455
12	1 3/16	+.001 +.003	1 7/32	+.015	2 3/16	.015	11/16	16 - 5/16	.41	4100	2700	1665	1195
13	1 1/4	+.001 +.003	1 9/32	+.015	2 3/16	.015	11/16	17 - 5/16	.38	4250	2800	1725	1240
14	1 3/16	+.001 +.003	1 7/32	+.015	2 13/32	.015	15/16	15 - 3/8	.75	5505	3625	2235	1605
15	1 1/4	+.001 +.003	1 9/32	+.015	2 13/32	.015	15/16	15 - 3/8	.70	5505	3625	2235	1605
16	1 5/16	+.001 +.003	1 11/32	+.015	2 13/32	.015	15/16	15 - 3/8	.69	5505	3625	2235	1605
17	1 5/16	+.001 +.003	1 11/32	+.015	2 13/32	.015	11/16	18 - 5/16	.50	4395	2895	1785	1280
17A	1 3/8	+.001 +.003	1 13/32	+.015	2 13/32	.015	11/16	19 - 5/16	.44	4525	2975	1835	1315

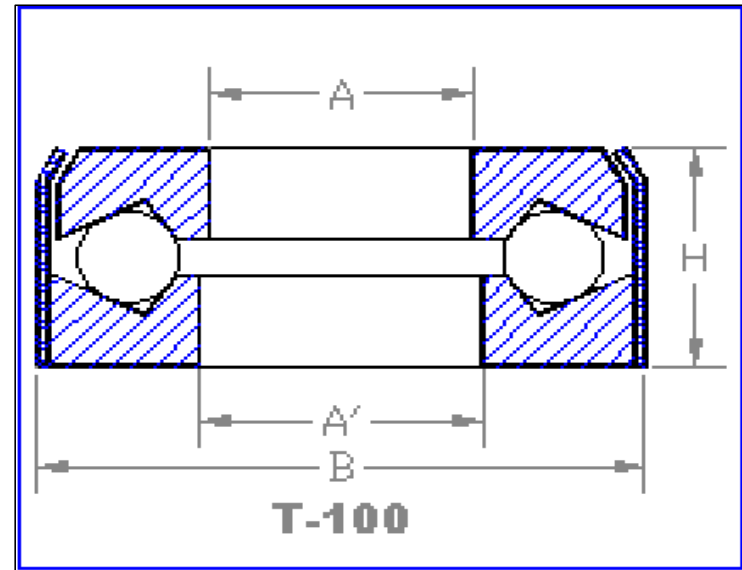

Auburn Bearing & Manufacturing T-100

DIMENSIONS IN INCHES

* H tolerance + or - .005

THRUST LOAD CAPACITY IN LBS. AT VARIOUS SPEEDS

Bearing Number	A Bore	A Tolerance	A' Bore	A' Tolerance -.000	B Outside Diameter	B Tolerance + or -	* H Height	Balls No. - Size	Bearing Weight	THRUST LOAD CAPACITY IN LBS. AT VARIOUS SPEEDS			
										25 RPM	100 RPM	500 RPM	1500 RPM
18	1 7/16	+.001 +.003	1 15/32	+.015	2 13/32	.015	11/16	19 - 5/16	.47	4525	2975	1835	1315
19	1 7/16	+.001 +.003	1 15/32	+.015	2 1/2	.015	15/16	16 - 3/8	.69	5730	3775	2325	1670
19A	1 3/8	+.001 +.003	1 13/32	+.015	2 1/2	.015	15/16	16 - 3/8	.75	5730	3775	2325	1670
20	1 7/16	+.001 +.003	1 15/32	+.015	2 19/32	.015	15/16	17 - 3/8	.77	5945	3915	2410	1735
21	1 1/2	+.001 +.003	1 17/32	+.015	2 19/32	.015	11/16	20 - 5/16	.52	4630	3050	1875	1350
22	1 1/2	+.001 +.003	1 17/32	+.015	2 19/32	.015	15/16	17 - 3/8	.72	5945	3915	2410	1735
23	1 5/8	+.001 +.003	1 21/32	+.015	2 19/32	.015	11/16	21 - 5/16	.51	4750	3130	1930	1385
24	1 11/16	+.001 +.003	1 23/32	+.015	2 19/32	.015	11/16	21 - 5/16	.47	4750	3130	1930	1385
25	1 13/16	+.001 +.003	1 27/32	+.015	2 3/4	.015	11/16	22 - 5/16	.53	4820	3175	1955	1405
26	1 11/16	+.001 +.003	1 23/32	+.015	2 3/4	.015	13/16	18 - 3/8	.69	6140	4045	2490	1790
27	1 7/8	+.001 +.003	1 29/32	+.015	2 3/4	.015	13/16	23 - 5/16	.56	4910	3235	1995	1430

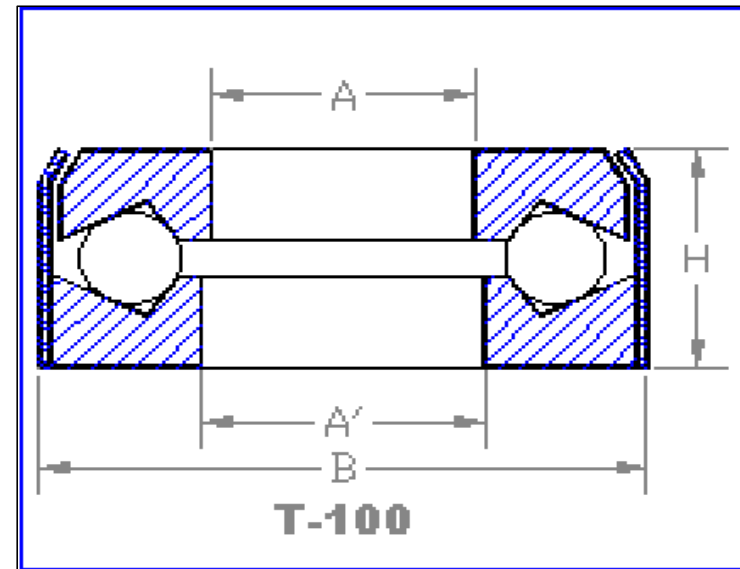

Auburn Bearing & Manufacturing T-100

DIMENSIONS IN INCHES

* H tolerance + or - .005

THRUST LOAD CAPACITY IN LBS. AT VARIOUS SPEEDS

Bearing Number	A Bore	A Tolerance	A' Bore	A' Tolerance -.000	B Outside Diameter	B Tolerance + or -	* H Height	Balls No. - Size	Bearing Weight	THRUST LOAD CAPACITY IN LBS. AT VARIOUS SPEEDS			
										25 RPM	100 RPM	500 RPM	1500 RPM
									in Lbs.				
28	1 9/16	+.001 +.003	1 19/32	+.015	2 3/4	.015	1	15 - 7/16	.94	7280	4795	2955	2120
29	1 5/8	+.001 +.003	1 21/32	+.015	3	.015	1 3/16	14 - 1/2	1.31	8830	5815	3580	2575
30	1 15/16	+.001 +.003	1 31/32	+.015	3	.015	13/16	20 - 3/8	.75	6485	4270	2630	1890
31	2	+.001 +.003	2 1/32	+.015	3	.015	13/16	20 - 3/8	.72	6485	4270	2630	1890
32	1 11/16	+.001 +.003	1 23/32	+.015	3 3/16	.015	1 1/8	15 - 1/2	1.44	9255	6095	3755	2825
33	2 3/16	+.001 +.003	2 7/32	+.015	3 3/16	.015	13/16	26 - 5/16	.78	5070	3340	2060	1480
34	1 3/4	+.001 +.003	1 25/32	+.015	3 3/16	.015	1 1/8	15 - 1/2	1.34	9255	6095	3755	2825
35	2 1/4	+.001 +.003	2 9/32	+.015	3 1/4	.015	13/16	22 - 3/8	.80	6755	4450	2740	1970
36	2 5/16	+.001 +.003	2 11/32	+.015	3 1/4	.015	13/16	28 - 5/16	.78	5130	3380	2085	1495
37	1 15/16	+.001 +.003	1 31/32	+.015	3 1/4	.015	1 3/16	16 - 1/2	1.44	9640	6350	3910	2810
38	2	+.001 +.003	2 1/32	+.015	3 1/4	.015	1 3/16	16 - 1/2	1.34	9640	6350	3910	2810

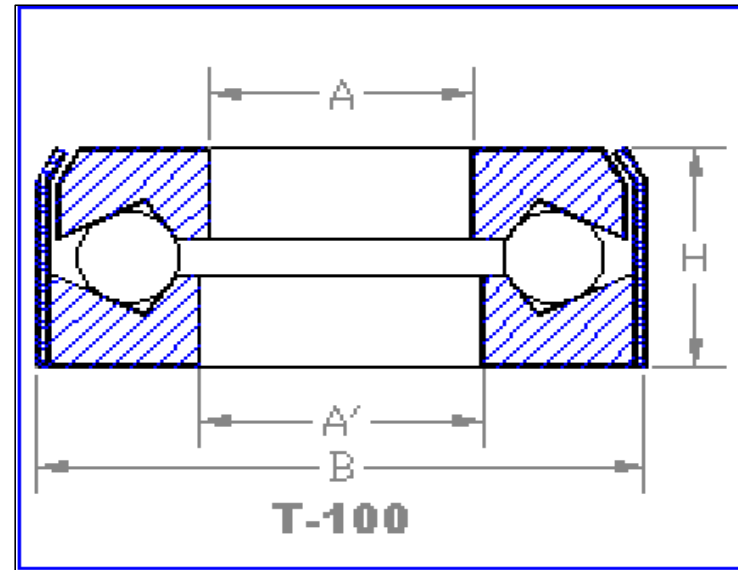

Auburn Bearing & Manufacturing T-100

Bearing Number	DIMENSIONS IN INCHES				* H tolerance + or - .005			THRUST LOAD CAPACITY IN LBS. AT VARIOUS SPEEDS					
	A Bore	A Tolerance	A' Bore	A' Tolerance -.000	B Outside Diameter	B Tolerance + or -	* H Height	Balls No. - Size	Bearing Weight in Lbs.	25 RPM	100 RPM	500 RPM	1500 RPM
39	2 3/16	+.001 +.003	2 7/32	+.015	3 7/8	.015	1 1/4	19 - 1/2	2.25	10635	7005	4315	3100
40	2 1/4	+.001 +.003	2 9/32	+.015	3 7/8	.015	1 1/4	19 - 1/2	2.13	10635	7005	4315	3100
41	2 7/16	+.001 +.003	2 15/32	+.015	4	.015	1 1/4	20 - 1/2	2.19	10900	7180	4425	3175
41A	1 15/16	+.001 +.003	1 31/32	+.015	4	.015	1 5/8	13 - 11/16	3.60	14690	9675	5960	4280
42	2 1/2	+.001 +.003	2 17/32	+.015	4	.015	1 1/4	20 - 1/2	2.13	10900	7180	4425	3175
43	2 15/16	+.001 +.003	2 31/32	+.015	4 5/8	.015	1 1/2	19 - 5/8	3.44	15780	10395	6405	4600
43A	2 3/4	+.001 +.003	2 25/32	+.015	4 5/8	.015	1 1/2	19 - 5/8	3.50	15780	10395	6405	4600
44	3	+.001 +.003	3 1/32	+.015	4 5/8	.015	1 1/2	19 - 5/8	3.38	15780	10395	6405	4600
45	3	+.001 +.003	3 1/32	+.015	4 5/8	.015	1	27 - 7/16	2.26	9460	6230	3840	2755
46	2 7/16	+.001 +.003	2 15/32	+.015	4 5/8	.015	1 5/8	16 - 11/16	4.60	16875	11115	6845	4920
47	3 7/16	+.002 +.004	3 15/32	+.015	5	.031	1	30 - 7/16	2.48	9490	6250	3850	---

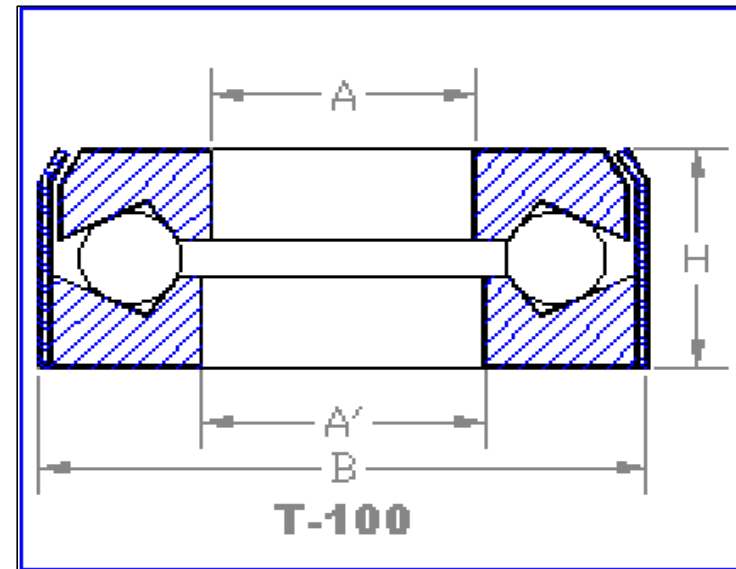

Auburn Bearing & Manufacturing T-100

DIMENSIONS IN INCHES

* H tolerance + or - .005

THRUST LOAD CAPACITY IN LBS. AT VARIOUS SPEEDS

Bearing Number	DIMENSIONS IN INCHES				B Outside Diameter	B Tolerance + or -	* H Height	Balls No. - Size	Bearing Weight in Lbs.	THRUST LOAD CAPACITY IN LBS. AT VARIOUS SPEEDS			
	A Bore	A Tolerance	A' Bore	A' Tolerance -.000						25 RPM	100 RPM	500 RPM	1500 RPM
48	2 3/16	+.001 +.003	2 7/32	+.015	5	.031	2 1/4	11 - 1	8.47	24490	16130	9935	---
49	4 1/2	+.003 +.007	4 9/16	+.015	6 1/4	.031	1 3/8	30 - 9/16	4.47	14860	9790	6030	---
50	3 7/16	+.002 +.004	3 15/32	+.015	6 1/4	.031	2	18 - 7/8	10.18	27300	17985	11080	---
51	3	+.001 +.003	3 1/32	+.015	6 1/4	.031	3	11 - 1 1/4	18.30	35110	23135	14245	---
52	4	+.002 +.004	4 1/32	+.015	6 7/8	.031	2	20 - 7/8	11.76	28840	18990	11700	---
53	4 7/16	+.003 +.007	4 1/2	+.015	6 7/8	.031	2 1/4	20 - 7/8	12.83	28840	18990	11700	---
54	5	+.003 +.007	5 1/16	+.015	7	.031	1 1/4	37 - 1/2	5.03	11135	7335	4520	---
56	6 1/2	+.010 +.015	6 9/16	+.015	8 3/4	.031	1 1/2	37 - 5/8	10.12	16540	10895	6710	---