

Auburn Bearing & Manufacturing T-114

BALL THRUST BEARING OPEN STYLE SELF CONTAINED "AUBURN" GROOVES

Auburn Open Style T-114 Ball Thrust Bearing is recommended for use in enclosed protected locations, inside the machine housing or where it is desired to operate it in an oil bath. It is self-contained, the two races and balls being held together as a unit by the inside sleeve.

When preloaded and installed so as to be held by the outside diameter "B" this bearing will carry a radial load equal to 25% of its thrust load capacity

MOUNTING INSTRUCTIONS:

Open Style T-114 Ball Thrust Bearing is usually installed so as to be centered by the rotating shaft through bore "A."

The race having the inside sleeve attached to it should rotate with the shaft. The race which is loose from the inside sleeve and having outside diameter "B" will seat against a fixed part of the machine and be stationary. If installed in a recess, a clearance of one-eighth inch, or more, should be left around the outside diameter "B" and "B'" so that if the shaft should wear in its journal bearings, the thrust bearing will be free to follow without cramping or wedging the balls.

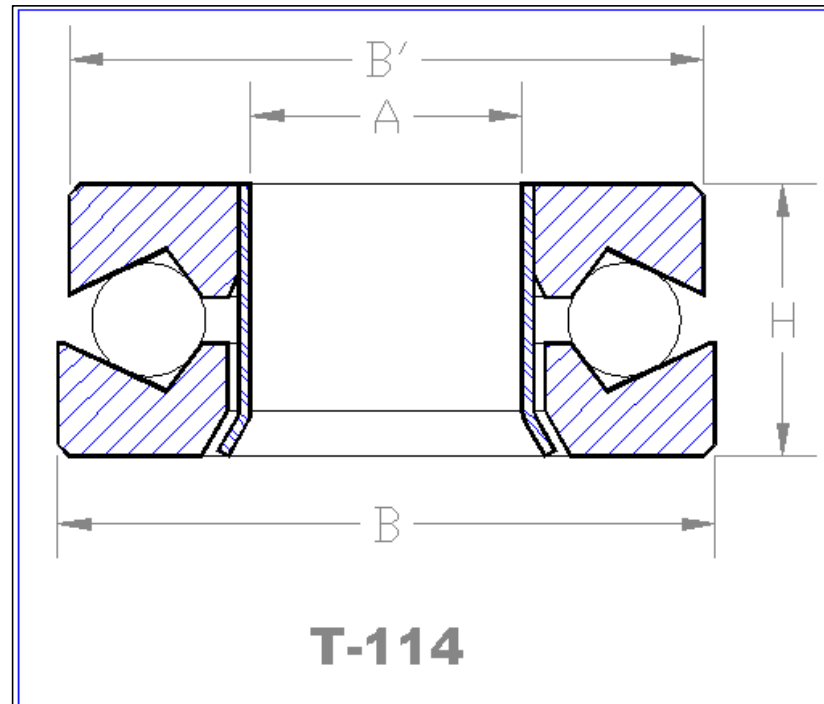

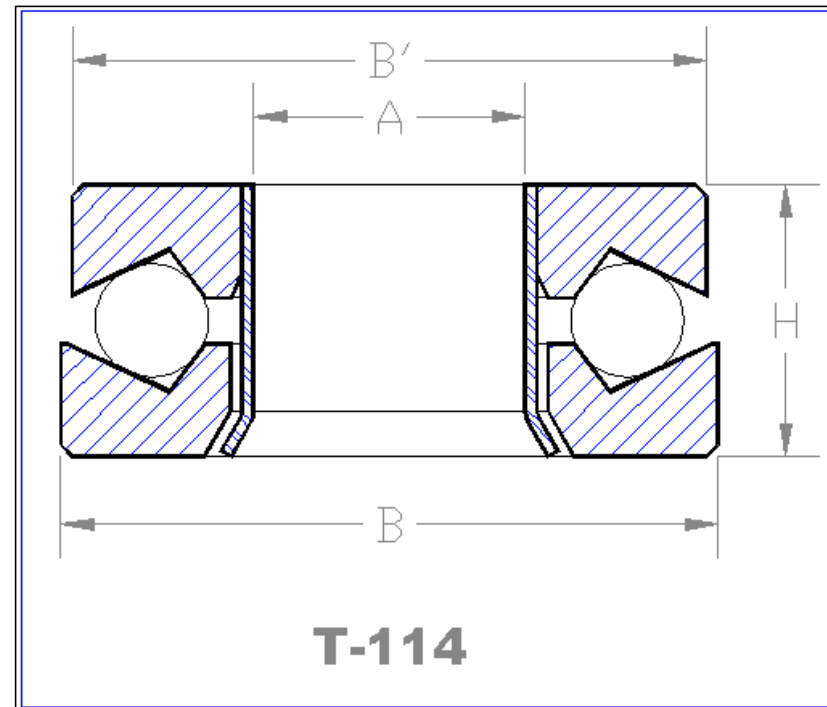

Auburn Bearing & Manufacturing T-114

Bearing Number	DIMENSIONS IN INCHES						* H Tolerance + or - .005								THRUST LOAD CAPACITY IN LBS. AT VARIOUS SPEEDS			
	A Bore	A Tolerance	B Outside Diameter	B Tolerance	B' Outside Diameter	B' Tolerance +.000	H Height*	Balls No. - Size	Bearing Weight in Lbs.	25 RPM	100 RPM	500 RPM	1500 RPM					
HEAVY TYPE																		
1	11/16	+0.001 +.003	1 15/16	+0.003 -.003	1 59/64	-.015	7/8	11 - 3/8	.50	4405	2900	1785	1285					
2	15/16	+0.001 +.003	2 7/16	+0.003 -.003	2 13/32	-.015	1	13 - 7/16	.88	6595	4345	2675	1925					
3	1 3/16	+0.001 +.003	2 11/16	+0.003 -.003	2 21/32	-.015	1 1/8	12 - 1/2	1.03	7910	5210	3210	2305					
4	1 7/16	+0.001 +.003	2 15/16	+0.003 -.003	2 29/32	-.015	1 1/8	14 - 1/2	1.34	8830	5815	3580	2575					
5	1 11/16	+0.001 +.003	3 3/16	+0.003 -.003	3 5/32	-.015	1 1/8	16 - 1/2	1.44	9640	6350	3910	2810					
6	1 15/16	+0.001 +.003	3 3/4	+0.003 -.003	3 23/32	-.015	1 1/4	17 - 9/16	2.22	12320	8115	5000	3590					
7	2 3/16	+0.001 +.003	4	+0.003 -.003	3 31/32	-.015	1 1/2	16 - 5/8	3.00	14285	9410	5795	4165					
8	2 7/16	+0.001 +.003	4 1/2	+0.003 -.003	4 15/32	-.015	1 5/8	16 - 11/16	3.75	16875	11115	6845	4920					
9	2 11/16	+0.001 +.003	4 3/4	+0.003 -.003	4 23/32	-.015	1 3/4	16 - 3/4	4.88	19615	12920	7960	---					
10	2 15/16	+0.001 +.003	5 1/8	+0.003 -.003	5 1/16	-.015	1 3/4	17 - 3/4	5.50	20345	13400	8255	---					
11	3 3/16	+0.002 +.004	5 1/2	+0.003 -.003	5 7/16	-.015	1 3/4	18 - 3/4	6.13	21005	13835	8525	---					

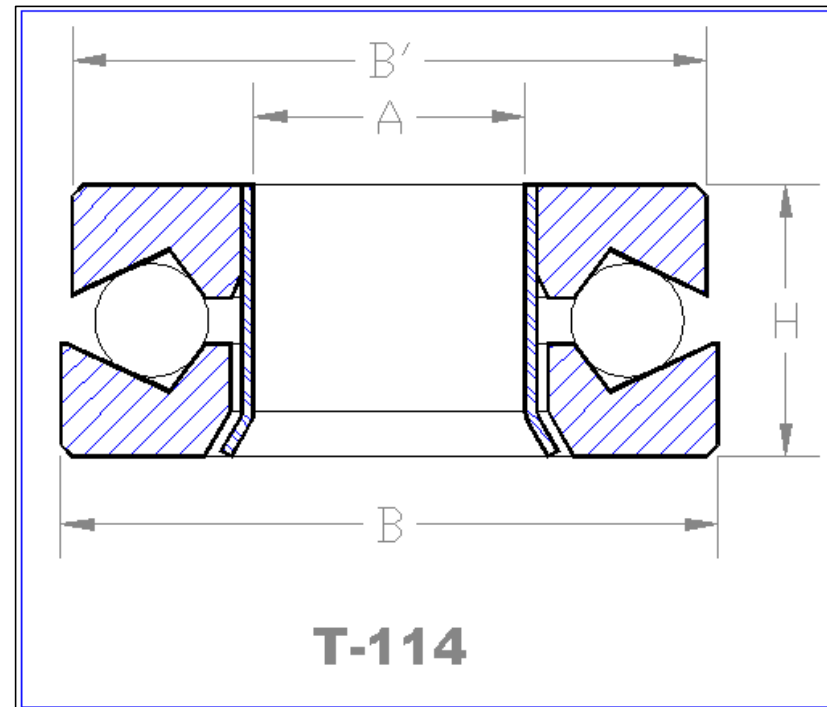

Auburn Bearing & Manufacturing T-114

Bearing Number	DIMENSIONS IN INCHES						* H Tolerance + or - .005								THRUST LOAD CAPACITY IN LBS. AT VARIOUS SPEEDS			
	A Bore	A Tolerance	B Outside Diameter	B Tolerance	B' Outside Diameter	B' Tolerance +.000	H Height*	Balls No. - Size	Bearing Weight in Lbs.	25 RPM	100 RPM	500 RPM	1500 RPM					
12	3 7/16	+.002 +.004	5 3/4	+.003 -.003	5 11/16	-.015	1 7/8	18 - 13/16	7.00	24085	15865	9775	---					
13	3 11/16	+.002 +.004	6 1/8	+.003 -.003	6 3/32	-.015	1 7/8	19 - 13/16	8.00	24815	16345	10070	---					
14	3 15/16	+.002 +.004	6 1/2	+.004 -.004	6 13/32	-.031	2	19 - 7/8	9.75	28140	18535	11420	---					
15	4 3/16	+.003 +.007	6 7/8	+.004 -.004	6 25/32	-.031	2 1/4	17 - 1	11.75	33050	21770	13410	---					
16	4 7/16	+.003 +.007	7 1/4	+.004 -.004	7 5/32	-.031	2 3/8	19 - 1	13.38	35170	23165	14270	---					
17	4 11/16	+.003 +.007	7 1/2	+.004 -.004	7 13/32	-.031	2 3/8	19 - 1	14.00	35170	23165	14270	---					
18	4 15/16	+.003 +.007	8 1/8	+.004 -.004	8 1/32	-.031	2 5/8	18 - 1 1/8	18.00	41395	27265	16795	---					
19	5 3/16	+.003 +.007	8 1/2	+.004 -.004	8 13/32	-.031	2 3/4	19 - 1 1/8	21.00	42640	28085	17300	---					
20	5 7/16	+.003 +.007	8 7/8	+.005 -.005	8 3/4	-.031	3	18 - 1 1/4	25.00	48970	32255	19870	---					
21	5 11/16	+.003 +.007	9 1/4	+.005 -.005	9 1/8	-.031	3	19 - 1 1/4	27.00	50420	33210	20460	---					
22	5 15/16	+.003 +.007	9 3/4	+.005 -.005	9 5/8	-.031	3 1/4	16 - 1 1/2	32.00	60655	39950	24610	---					
23	6 3/16	+.010 +.015	10 1/8	+.005 -.005	10	-.031	3 3/8	17 - 1 1/2	36.00	63000	41495	25560	---					

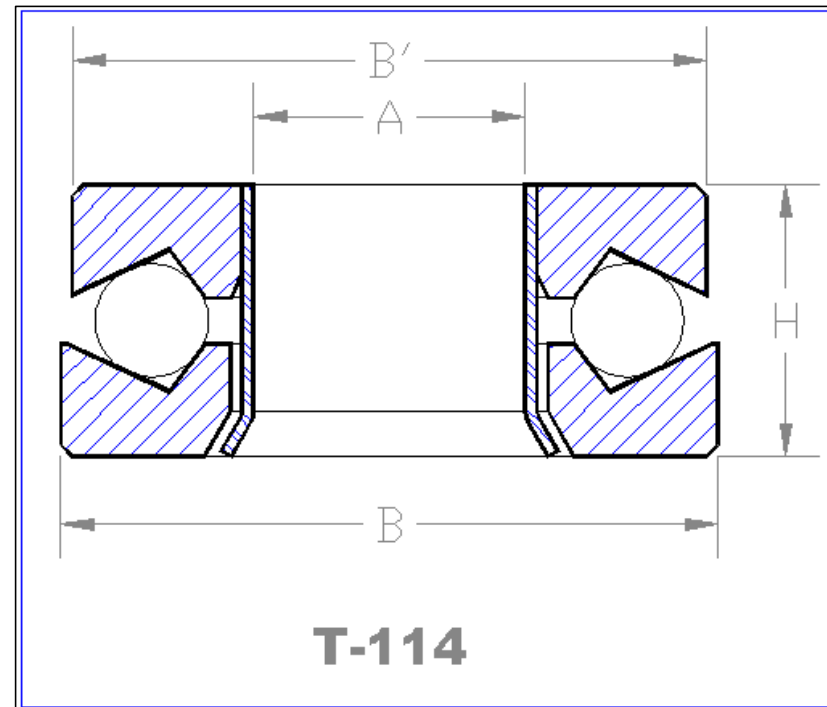

Auburn Bearing & Manufacturing T-114

Bearing Number	DIMENSIONS IN INCHES * H Tolerance + or - .005								THRUST LOAD CAPACITY IN LBS. AT VARIOUS SPEEDS				
	A Bore	A Tolerance	B Outside Diameter	B Tolerance	B' Outside Diameter	B' Tolerance +.000	H Height*	Balls No. - Size	Bearing Weight in Lbs.	25 RPM	100 RPM	500 RPM	1500 RPM
24	6 7/16	+.010 +.015	10 5/8	+.005 -.005	10 1/2	-.031	3 3/4	18 - 1 1/2	44.00	65085	42870	26410	---
MEDIUM TYPE													
25	7/16	+.001 +.003	1 1/8	+.001 -.001	1 7/64	-.015	5/8	12 - 7/32	.09	1730	1140	700	505
26	5/8	+.001 +.003	1 7/16	+.002 -.002	1 27/64	-.015	11/16	14 - 1/4	.17	2480	1635	1005	725
27	3/4	+.001 +.003	1 1/2	+.002 -.002	1 31/64	-.015	11/16	17 - 7/32	.22	2185	1440	890	635
28	3/4	+.001 +.003	1 3/4	+.002 -.002	1 47/64	-.015	11/16	13 - 5/16	.31	3570	2350	1450	1040
29	13/16	+.001 +.003	1 15/16	+.003 -.003	1 59/64	-.015	13/16	14 - 5/16	.47	3760	2475	1525	1095
30	11/16	+.001 +.003	1 15/16	+.003 -.003	1 59/64	-.015	13/16	14 - 5/16	.50	3760	2475	1525	1095
31	15/16	+.001 +.003	2 1/8	+.003 -.003	2 3/32	-.015	3/4	15 - 5/16	.55	3940	2595	1600	1150
32	1 1/8	+.001 +.003	2 11/32	+.003 -.003	2 5/16	-.015	15/16	15 - 3/8	.67	5505	3625	2235	1605
33	1 3/16	+.001 +.003	2 11/32	+.003 -.003	2 5/16	-.015	15/16	15 - 3/8	.66	5505	3625	2235	1605

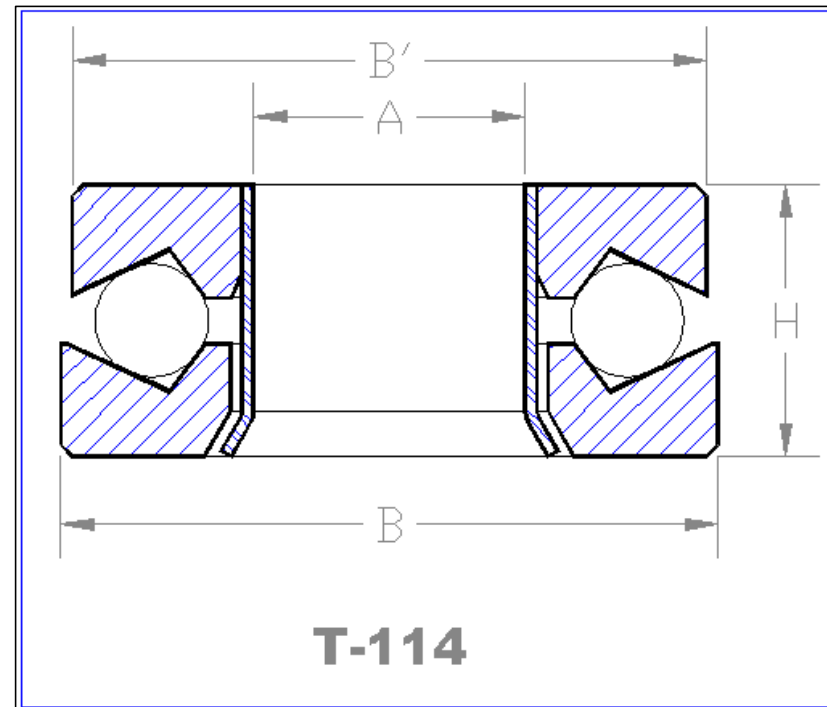

Auburn Bearing & Manufacturing T-114

Bearing Number	DIMENSIONS IN INCHES							* H Tolerance + or - .005							THRUST LOAD CAPACITY IN LBS. AT VARIOUS SPEEDS			
	A Bore	A Tolerance	B Outside Diameter	B Tolerance	B' Outside Diameter	B' Tolerance +.000	H Height*	Balls No. - Size	Bearing Weight in Lbs.	25 RPM	100 RPM	500 RPM	1500 RPM					
34	1 5/16	+.001 +.003	2 7/16	+.003 -.003	2 13/32	-.015	15/16	16 - 3/8	.67	5730	3775	2325	1670					
35	1 7/16	+.001 +.003	2 11/16	+.003 -.003	2 21/32	-.015	7/8	17 - 3/8	.81	5945	3915	2410	1735					
36	1 11/16	+.001 +.003	2 11/16	+.003 -.003	2 21/32	-.015	13/16	23 - 5/16	.63	4910	3235	1995	1430					
37	1 13/16	+.001 +.003	2 15/16	+.003 -.003	2 29/32	-.015	15/16	20 - 3/8	.89	6485	4270	2630	1890					
38	1 1/2	+.001 +.003	2 15/16	+.003 -.003	2 29/32	-.015	1 3/16	14 - 1/2	1.50	8830	5815	3500	2575					
39	1 11/16	+.001 +.003	3 1/8	+.003 -.003	3 3/32	-.015	1 1/8	15 - 1/2	1.28	9255	6095	3755	2825					
40	1 15/16	+.001 +.003	3 3/16	+.003 -.003	3 5/32	-.015	1 3/16	19 - 7/16	1.34	8365	5510	3395	2440					
41	2 1/16	+.001 +.003	3 1/4	+.003 -.003	3 7/32	-.015	1	19 - 7/16	1.13	8365	5510	3395	2440					
42	2 3/16	+.001 +.003	3 1/4	+.003 -.003	3 7/32	-.015	1 1/8	23 - 3/8	2.09	6870	4525	2785	2005					
43	2 3/16	+.001 +.003	3 3/4	+.003 -.003	3 23/32	-.015	1 1/4	19 - 1/2	2.13	10635	7005	4315	3100					
44	2 5/16	+.001 +.003	3 15/16	+.003 -.003	3 29/32	-.015	1 1/4	20 - 1/2	2.31	10900	7180	4425	3175					
45	2 7/16	+.001 +.003	3 15/16	+.003 -.003	3 29/32	-.015	1 1/4	20 - 1/2	2.06	10900	7180	4425	3175					

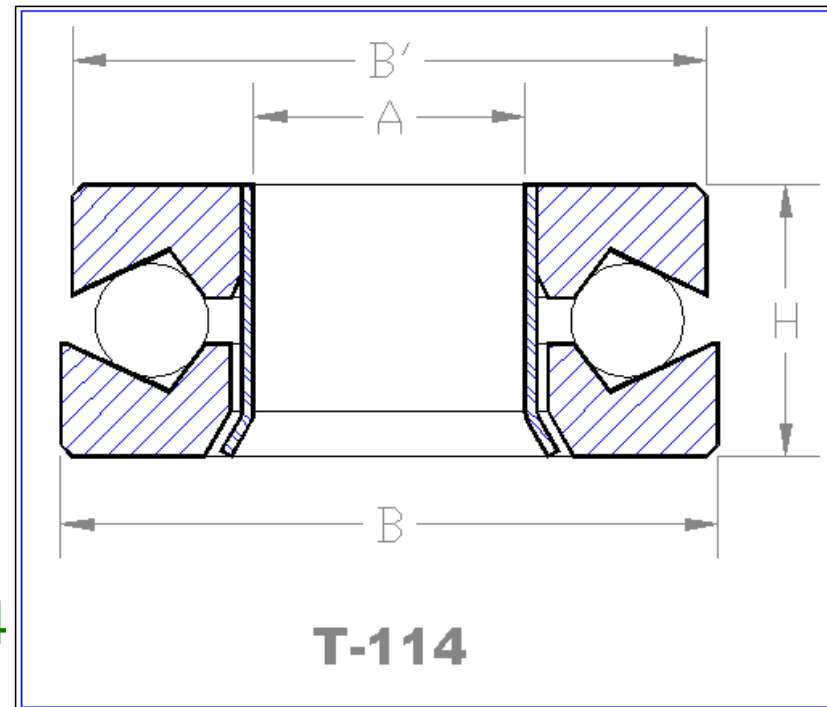

Auburn Bearing & Manufacturing T-114

Bearing Number	DIMENSIONS IN INCHES							* H Tolerance + or - .005							THRUST LOAD CAPACITY IN LBS. AT VARIOUS SPEEDS			
	A Bore	A Tolerance	B Outside Diameter	B Tolerance	B' Outside Diameter	B' Tolerance +.000	H Height*	Balls No. - Size	Bearing Weight in Lbs.	25 RPM	100 RPM	500 RPM	1500 RPM					
46	2 11/16	+.001 +.003	4 1/2	+.003 -.003	4 15/32	-.015	1 1/2	18 - 5/8	3.25	15325	10095	6220	4470					
47	2 15/16	+.001 +.003	4 1/2	+.003 -.003	4 15/32	-.015	1 1/2	20 - 19/32	3.00	14780	9740	6000	4310					
48	2 13/16	+.001 +.003	4 1/2	+.003 -.003	4 15/32	-.015	1 1/2	18 - 5/8	3.13	15325	10095	6220	---					
49	3 7/16	+.002 +.004	5 3/8	+.003 -.003	5 5/16	-.015	1 1/2	22 - 5/8	4.25	16860	11105	6840	---					
50	3 15/16	+.002 +.004	5 7/8	+.003 -.003	5 13/16	-.015	1 1/2	25 - 5/8	5.00	17575	11575	7130	---					
51	4 7/16	+.003 +.007	6 1/4	+.003 -.003	6 3/16	-.015	1 1/2	27 - 5/8	5.25	17830	11745	7235	---					
52	4 15/16	+.003 +.007	7	+.004 -.004	6 29/32	.031	1 1/2	30 - 5/8	6.63	17900	11790	7265	---					
53	5 7/16	+.003 +.007	7 1/2	+.004 -.004	7 13/32	.031	1 3/4	27 - 3/4	8.75	24495	16135	9940	---					
54	5 15/16	+.003 +.007	8	+.004 -.004	7 29/32	.031	1 3/4	29 - 3/4	10.00	24600	16205	9985	---					